

TRUCK CRANE

ZTC800V532



ZOOMLION

Zoomlion Heavy Industry Science & Technology Co.,Ltd.

Add: No.677, Lugu Road, Zoomlion Industrial Park, Changsha, Hunan, China, 410205

Copyright©2017 Zoomlion. All rights reserved. Reproduction and copying of any part of contents is not allowed for any purposes without Zoomlion's approval.



websiteen.zoomlion.com

ZOOMLION

4.0
PRODUCTS

Vision Creates Future

CONTENTS

ZTC800V	Highlights	01 / 02
ZTC800V	Key Features	03 / 04
ZTC800V	Main Technical Parameters	05
ZTC800V	Overall Dimensions in Driving Condition / Lifting Height Chart	06
ZTC800V	Lifting capacity tables	07 / 08





2646
KN*M

Max. Lifting Moment

2.5
M/Min

Min. Stable Hoisting Speed

63.8
M

Max. Lifting Height
(Main boom + jib)



Excellent performance with energy saving, comfort and reliability

- Innovative new boom head structure, 5-section U-shaped 47m main boom with superior comprehensive lifting capacity, max. lifting moment 2646KN*M, max. lifting height (main boom+ jib) 63.8M.
- Intelligent multi-power mode energy saving system, average oil consumption lower than 4.5L/H, saving fuel up to 20% comprehensively.
- Innovative new load-sensing slewing system, proportional main valve offers better micro-positioning performance(min. stable slewing speed 0.1°/S, min. stable hoisting speed 2.5M/Min).
- Reliability-proven golden driving chain adopted, with better off-road performance and gradeability reaches 46%.



Strong Lifting Capacity

- 1.5-section U-shaped 47M main boom, max. lifting moment 2646KN*M, comprehensive lifting capacity surpass others by 5%-15%.
2. Its innovative new boom head and end structure, with optimized boom connections provide with stronger load-bearing capacity.
3. 2nd generation of arbitrary telescoping technology enables more stable telescoping and greatly enhances its anti-rollover performance.



Stable and Safe Lifting Performance

1. Innovative new load-sensing slewing system, proportional main valve offers better micro-positioning performance (min. stable slewing speed 0.1°/S, min. stable hoisting speed 2.5M/Min).
2. LUDV hydraulic system enables the crane to realize four movements simultaneously with high efficiency.
3. Independent radiator system, hydraulic system temperature is controlled within 75°C.



Classic driving chain & heavy-duty chassis platform

1. Powerful low speed and high moment driving chain guarantees high safety and reliability.
2. Brand-new rubber suspension and V-shaped thrust rod technology enables better driving experience and can effectively extend tires' working life.
3. Power-assist gear shift mechanism makes the operating with less fatigue.



Intelligence & Environment-Friendly

1. Intelligent multi-power mode energy saving system offers an average 4.5L/H oil consumption, saving fuel up to 20% comprehensively.
2. In-vehicle information system enables you fully and real-time monitor your machine in an easy way.
3. Noise is greatly cut down and can reach CE standard.



Modern and High-Class, Comfortable and Endurable

1. Brand-new green and grey VI Painting offers a better visual enjoyment.
2. Luxury truck driver's cab with spacious cab room and comfortable driving experience, standard full view tilt-able operator's cab offers easy and safe operation.
3. The flow of AC system can be automatically adjusted for comfortable operating environment.
4. The reliability of hydraulic and electronic system is optimized, offers longer working life and easy maintenance.

Item		Value	Remarks
Work performance	Max. rated lifting capacity	kg	80000
	Max. load moment of basic boom	kN.m	2646
	Max. load moment of main boom (fully extended)	kN.m	1288
	Max. lifting height of basic boom	m	13.4
	Max. lifting height of main boom (fully extended)	m	47.7
	Max. lifting height of jib	m	63.8
Work speeds	Max. hoist rope speed (Main winch)	m/min	125
	Max. hoist rope speed (Auxiliary winch)	m/min	110
	Boom derricking up time	s	55
	Boom telescoping out time	s	120
Driving	Slewing speed	r/min	0~1.7
	Max. driving speed	km/h	85
	Max. gradeability	%	46
	Min. turning diameter	m	≤24
	Min. ground clearance	mm	305
	Oil consumption per hundred kilometer	L	45
Mass	Deadweight in driving condition	kg	46000
	Complete vehicle kerb mass	kg	45805
	Front axle load	kg	20000
	Rear axle load	kg	26000
Dimensions	Overall dimensions (L × W × H)	mm	14500 × 2800 × 3850
	Outrigger spread (L)	m	6.05
	Outrigger spread (W)	m	Fully extended:7.8
	Tail slewing radius	mm	4200
	Main boom length	m	12.1 ~ 47.0
	Boom angle	°	-2 ~ 80
	Jib length	m	9.5、16.0
	Offset	°	0、15、30

These parameters do not include deflection of main boom and jib.

At 4th layer
At 2nd layer

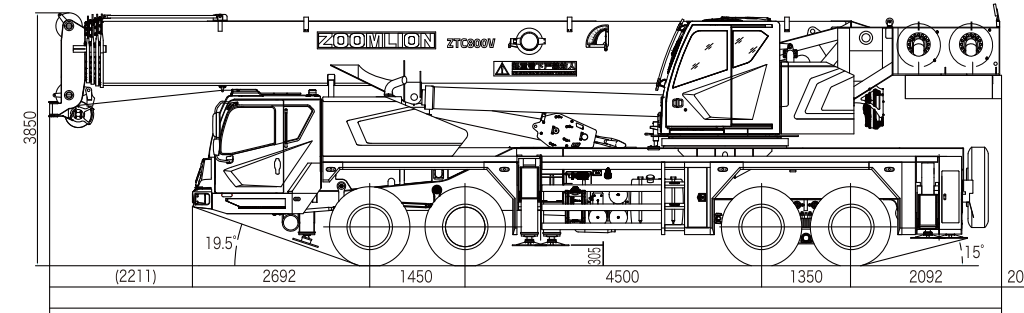

Size units(mm)

Right-hand drive ZTC800R532 is also available!

Lifting height curve

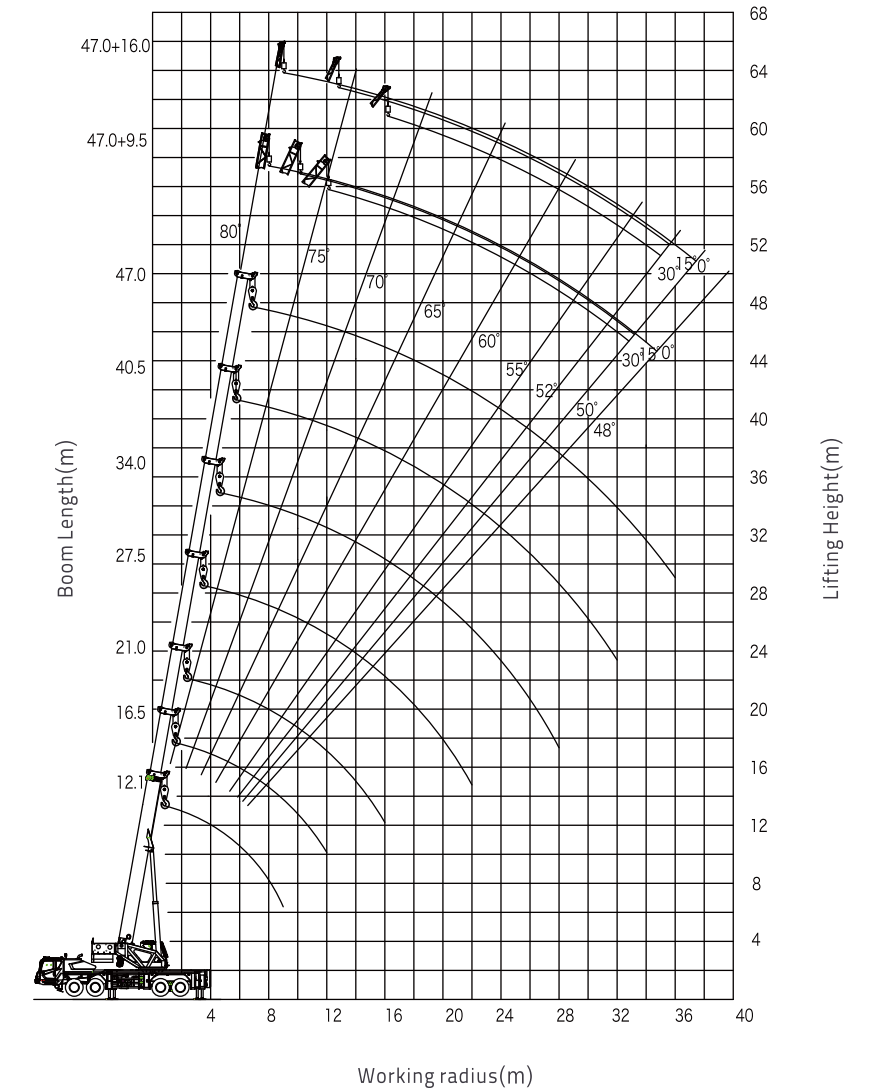

Table1 Unit:kg

Working Radius (m)	Main boom (m)						
	Telescoping cylinder I & outriggers fully extended, over sides and rear, 5t counterweight						
	12.1	16.5	21.0	27.5	34.0	40.5	47.0
3.0	80000*	55000					
3.5	67000*	53000	43500				
4.0	57000	52000	43500				
4.5	54000	49000	42000	31000			
5.0	50000	46000	41000	31000			
5.5	47000	44000	39000	30000			
6.0	43000	41000	37000	29000	23000		
7.0	33000	32500	32000	27000	22000		
8.0	25000	24500	24000	24500	21000	16500	
9.0	19500	19000	18500	20500	19500	15500	
10.0		15000	14500	16500	17200	14500	11500
11.0		12500	12000	13500	14500	13500	11000
12.0		10500	10000	11500	12500	12500	10500
14.0			7000	8500	9200	10000	9300
16.0			5000	6200	7000	7600	8000
18.0				4700	5400	6000	6300
20.0				3500	4200	4700	5100
22.0				2500	3200	3700	4100
24.0					2400	3000	3300
26.0					1800	2300	2600
28.0					1200	1700	2100
30.0						1200	1600
32.0						1000	1200
34.0							1000
I	0	4.4	8.9	8.9	8.9	8.9	8.9
II	0	0	0	6.5	13.0	19.5	26
Reeving	12	10	8	6	5	4	3
Hook	60t Hook						

Table2 Unit:kg

Working Radius (m)	Main boom (m)					
	Telescoping cylinder I half extended, outriggers fully extended, over sides and rear, 5t counterweight					
	12.1	16.5	23.0	29.5	36.0	42.5
3.0	80000*	55000				
3.5	67000*	53000	31000			
4.0	57000	52000	31000			
4.5	54000	49000	31000			
5.0	50000	46000	31000	23000		
5.5	47000	44000	30000	23000		
6.0	43000	41000	29000	23000		
7.0	33000	32500	27000	22000	16500	
8.0	25000	24500	26500	21000	16500	12000
9.0	19500	19000	21000	19500	15500	11500
10.0		15000	17000	18000	14500	11500
11.0		12500	14200	15200	13500	11000
12.0		10500	12000	13000	12500	10500
14.0			8800	9700	10200	9300
16.0			6600	7500	8000	8100
18.0			5000	5800	6300	6700
20.0				4600	5000	5400
22.0				3600	4100	4400
24.0				2800	3300	3600
26.0					2600	3000
28.0					2100	2400
30.0					1600	1900
32.0						1500
34.0						1200
36.0						
I	0	4.4	4.4	4.4	4.4	4.4
II	0	0	6.5	13.0	19.5	26
Reeving	12	10	6	6	4	3
Hook	60t Hook					

Note: Those points marked with "*" are only applicable by using 80T hook, and lifting area is over sides and rear.

Table3 Unit:kg

Working Radius (m)	Main boom (m)				
	Telescoping cylinder I fully retracted, outriggers fully extended, over sides and rear, 5t counterweight				
	12.1	18.6	25.1	31.6	38.1
3.0	80000*	31000			
3.5	67000*	31000			
4.0	57000	31000	23000		
4.5	54000	31000	23000		
5.0	50000	31000	23000		
5.5	47000	30000	23000	16500	
6.0	43000	29000	23000	16500	
7.0	33000	27000	22000	16000	12500
8.0	25000	26500	21000	14500	12000
9.0	19500	21700	19500	13500	11500
10.0		17800	18000	12500	11500
11.0		15000	16000	11500	10500
12.0		12700	13500	10700	9700
14.0		9500	10200	9300	8400
16.0			8000	8200	7300
18.0			6400	6800	6400
20.0			5100	5500	5800
22.0				4500	4900
24.0				3700	4000
26.0				3100	3400
28.0					2800
30.0					2300
32.0					1900
34.0					
36.0					
I	0	0	0	0	0
II	0	6.5	13.0	19.5	26
Reeving	12	6	5	4	3
Hook	60t Hook				

Note: Those points marked with "*" are only applicable by using 80T hook, and lifting area is over sides and rear.

Table4 Unit:kg

Working Radius (m)	Main boom (m)						
	Telescoping cylinder I fully extended, outriggers half extended, over sides and rear, 5t counterweight						
	12.1	16.5	21.0	27.5	34.0	40.5	47.0
3.0	62000*	52000					
3.5	52000	48000	42000				
4.0	45000	43000	40000				
4.5	40000	38000	37000	31000			
5.0	38000	36000	34000	31000			
5.5	30500	30000	29000	30000			
6.0	25000	24500	24000	25000	23000		
7.0	18000	17500	17000	19000	19500		
8.0	13500	13000	12500	14500	15500	16500	
9.0	10500	10000	9600	11300	12000	13000	
10.0		8000	7600	9000	9900	10500	11500
11.0		6200	5800	7300	8100	8700	9300
12.0		5000	4600	6000	6700	7300	7800
14.0			2700	4000	4700	5200	5700
16.0			1300	2500	3200	3700	4200
18.0				1500	2200	2700	3100
20.0					1300	1800	2200
22.0						1100	1600
24.0							1000
26.0							
28.0							
30.0							
I	0	4.4	8.9	8.9	8.9	8.9	8.9
II	0	0	0	6.5	13.0	19.5	26
Reeving	12	10	8	6	5	4	3
Hook	60t Hook						

Table5 Unit:kg

Working Radius (m)	Main boom (m)					
	Telescoping cylinder I & outriggers half extended, over sides and rear, 5t counterweight					
	12.1	16.5	23.0	29.5	36.0	42.5
3.0	62000*	52000				
3.5	52000	48000	31000			
4.0	45000	43000	31000			
4.5	40000	38000	31000			
5.0	38000	36000	31000	23000		
5.5	30500	30000	30000	23000		
6.0	25000	24500	26000	23000		
7.0	18000	17500	19500	20500	16500	
8.0	13500	13000	15000	16000	16000	12000
9.0	10500	10000	11800	12700	13500	11500
10.0		8000	9500	10400	11000	11500
11.0		6200	7700	8600	9200	9600
12.0		5000	6400	7200	7700	8100
14.0			4200	5100	5600	6000
16.0			3000	3700	4100	4500
18.0			1900	2600	3000	3400
20.0				1800	2200	2500
22.0				1100	1500	1900
24.0					1000	1300
26.0						1000
28.0						
30.0						
I	0	4.4	4.4	4.4	4.4	4.4
II	0	0	6.5	13.0	19.5	26
Reeving	12	10	6	6	4	3
Hook	60t Hook					

Table6 Unit:kg

Working Radius (m)	Main boom (m)				
	Telescoping cylinder I fully retracted, outriggers half extended, over sides and rear, 5t counterweight				
	12.1	18.6	25.1	31.6	38.1
3.0	62000*	31000			
3.5	52000	31000			
4.0	45000	31000	23000		
4.5	40000	31000	23000		
5.0	38000	31000	23000		
5.5	30500	30000	23000	16500	
6.0	25000	27500	23000	16500	
7.0	18000	20000	21500	16500	12500
8.0	13500	15500	16500	14500	12000
9.0	10500	12500	13500	13000	11500
10.0		10200	11000	11500	11500
11.0		8400	9200	9700	10500
12.0		7000	7700	8300	8600
14.0		5000	5700	6100	6500
16.0			4200	4600	4900
18.0			3100	3500	3800
20.0			2300	2600	2900
22.0				2000	2300
24.0				1500	1600
26.0				1000	1300
28.0					1000
30.0					
I	0	0	0	0	0
II	0	6.5	13.0	19.5	26
Reeving	12	6	5	4	3
Hook	60t Hook				

Note: Those points marked with "*" are only applicable by using 80T hook, and lifting area is over sides and rear.

Table7 Unit:kg

Boom Angle (°)	Main Boom(m)+ Jib(m)					
	Outriggers fully extended, over sides and rear, 5t counterweight					
	47.0+9.5			47.0+16.0		
	0°	15°	30°	0°	15°	30°
80	5500	3500	3000	3500	2200	1500
78	5000	3500	3000	3500	2000	1500
76	5000	3300	2800	3200	2000	1500
74	4800	3300	2800	2800	2000	1500
72	4300	3100	2800	2800	1800	1400
70	4000	3000	2700	2600	1600	1400
68	3800	3000	2600	2400	1600	1400
66	3400	2900	2500	2300	1500	1400
64	2900	2600	2400	2200	1500	1300
62	2500	2300	2100	1900	1500	1300
60	2100	1900	1800	1700	1400	1300
58	1700	1600	1500	1400	1200	1100
56	1400	1300	1200	1100	1000	900
54	1200	1100	1000	900		
52	1000	900				
Reeving	1					
Hook	6t Hook					

Note: Those points marked with "*" are only applicable by using 80T hook, and lifting area is over sides and rear.

Table8 Unit:kg

Working Radius (m)	Main boom (m)						
	Telescoping cylinder I & outriggers fully extended, over sides and rear, 5t + 3t counterweight						
	12.1	16.5	21.0	27.5	34.0	40.5	47.0
3.0	80000*	55000					
3.5	67000*	53000	43500				
4.0	57000	52000	43500				
4.5	54000	49000	42000	31000			
5.0	50000	46000	41000	31000			
5.5	48000	44000	39000	30000			
6.0	45000	41000	37000	29000	23000		
7.0	37000	36500	33000	27000	22000		
8.0	28000	27000	27500	24500	21000	16500	
9.0	22000	21500	21500	22000	19500	15500	
10.0		17000	17300	18800	17200	14500	11500
11.0		14000	14300	15500	16000	13500	11000
12.0		12000	11800	13200	14000	12500	10500
14.0			8500	9600	10300	10600	9300
16.0			6200	7300	8000	8600	8100
18.0				5600	6300	6900	7300
20.0				4300	5100	5500	6000
22.0				3300	4000	4500	4800
24.0					3100	3600	4000
26.0					2400	2900	3200
28.0					1800	2300	2600
30.0						1800	2100
32.0						1400	1700
34.0							1300
36.0							1000
I	0	4.4	8.9	8.9	8.9	8.9	8.9
II	0	0	0	6.5	13.0	19.5	26
Reeving	12	10	8	6	5	4	3
Hook	60t Hook						

Table9 Unit:kg

Working Radius (m)	Main boom (m)					
	Telescoping cylinder I half extended, outriggers fully extended, over sides and rear, 5t + 3t counterweight					
	12.1	16.5	23.0	29.5	36.0	42.5
3.0	80000*	55000				
3.5	67000*	53000	31000			
4.0	57000	52000	31000			
4.5	54000	49000	31000			
5.0	50000	46000	31000	23000		
5.5	48000	44000	30000	23000		
6.0	45000	41000	29000	23000		
7.0	37000	36500	27000	22000	16500	
8.0	28000	27000	26000	21000	16500	12000
9.0	22000	21500	23500	19500	15500	11500
10.0		17000	19300	19000	14500	11500
11.0		14000	16200	17100	13500	11000
12.0		12000	13700	14600	12500	10500
14.0			10200	11000	10600	9300
16.0			7800	8600	9100	8100
18.0			6000	6800	7300	7300
20.0				5400	5900	6300
22.0				4400	4800	5200
24.0				3500	4000	4300
26.0					3200	3600
28.0					2600	2900
30.0					2100	2400
32.0						2000
34.0						1600
36.0						
I	0	4.4	4.4	4.4	4.4	4.4
II	0	0	6.5	13.0	19.5	26
Reeving	12	10	6	6	4	3
Hook	60t Hook					

Table10 Unit:kg

Working Radius (m)	Main boom (m)				
	Telescoping cylinder I fully retracted, outriggers fully extended, over sides and rear, 5t + 3t counterweight				
	12.1	18.6	25.1	31.6	38.1
3.0	80000*	31000			
3.5	67000*	31000			
4.0	57000	31000	23000		
4.5	54000	31000	23000		
5.0	50000	31000	23000		
5.5	48000	30000	23000	16500	
6.0	45000	29000	23000	16500	
7.0	37000	27000	22000	16000	12500
8.0	28000	26000	21000	14500	12000
9.0	22000	24000	19500	13500	11500
10.0		20000	18000	12500	11500
11.0		16800	17100	11500	10500
12.0		14300	15200	10700	9700
14.0		10800	11600	9300	8400
16.0			9100	8200	7300
18.0			7300	7300	6400
20.0			6000	6400	5800
22.0				5300	5200
24.0				4400	4600
26.0				3700	4000
28.0					3300
30.0					2800
32.0					2300
34.0					
36.0					
I	0	0	0	0	0
II	0	6.5	13.0	19.5	26
Reeving	12	6	5	4	3
Hook	60t Hook				

Table11 Unit:kg

Working Radius (m)	Main boom (m)						
	Telescoping cylinder I fully extended, outriggers half extended, over sides and rear, 5t + 3t counterweight						
	12.1	16.5	21.0	27.5	34.0	40.5	47.0
3.0	62000*	52000					
3.5	52000	48000	42000				
4.0	45000	43000	40000				
4.5	40000	38000	37000	31000			
5.0	38000	36000	34000	31000			
5.5	34000	33500	31500	30000			
6.0	28000	27500	25000	26000	23000		
7.0	21000	20000	19500	21000	21500		
8.0	16000	15500	15000	16700	17500	16500	
9.0	12000	12000	11500	13200	14200	15000	
10.0		9500	9300	10700	11500	12200	11500
11.0		7700	7500	8700	9500	10200	10500
12.0		6200	6000	7200	8000	8600	9000
14.0			3800	5000	5700	6200	6600
16.0			2300	3400	4100	4600	5000
18.0				2300	3000	3400	3800
20.0				1400	2000	2500	2800
22.0					1300	1800	2100
24.0						1200	1500
26.0							1000
28.0							
30.0							
I	0	4.4	8.9	8.9	8.9	8.9	8.9
II	0	0	0	6.5	13.0	19.5	26
Reeving	12	10	8	6	5	4	3
Hook	60t Hook						

Table12 Unit:kg

Working Radius (m)	Main boom (m)					
	Telescoping cylinder I & outriggers half extended, over sides and rear, 5t + 3t counterweight					
	12.1	16.5	23.0	29.5	36.0	42.5
3.0	62000*	52000				
3.5	52000	48000	31000			
4.0	45000	43000	31000			
4.5	40000	38000	31000			
5.0	38000	36000	31000	23000		
5.5	34000	33500	30000	23000		
6.0	28000	27500	26000	23000		
7.0	21000	20000	22000	22500	16500	
8.0	16000	15500	17200	18200	16000	12000
9.0	12000	12000	13700	14600	15000	11500
10.0		9500	11200	12000	12600	11500
11.0		7700	9200	10000	10500	11000
12.0		6200	7700	8500	9000	9500
14.0			5500	6200	6700	7100
16.0			3800	4600	5000	5400
18.0			2600	3300	3800	4100
20.0				2400	2900	3200
22.0				1600	2100	2400
24.0					1500	1800
26.0					1000	1300
28.0						1000
30.0						
I	0	4.4	4.4	4.4	4.4	4.4
II	0	0	6.5	13.0	19.5	26
Reeving	12	10	6	6	4	3
Hook	60t Hook					

Table13 Unit:kg

Working Radius (m)	Main boom (m)				
	Telescoping cylinder I fully retracted, outriggers half extended, over sides and rear, 5t + 3t counterweight				
	12.1	18.6	25.1	31.6	38.1
3.0	62000*	31000			
3.5	52000	31000			
4.0	45000	31000	23000		
4.5	40000	31000	23000		
5.0	38000	31000	23000		
5.5	34000	30000	23000	16500	
6.0	28000	29000	23000	16500	
7.0	21000	23000	22500	16500	12500
8.0	16000	18000	19000	14500	12000
9.0	12000	14500	15300	13200	11500
10.0		11800	12600	12300	11500
11.0		9800	10500	11000	10500
12.0		8300	9000	9600	9300
14.0		6000	6700	7200	7500
16.0			5100	5500	5800
18.0			3900	4300	4500
20.0			2900	3300	3600
22.0				2600	2800
24.0				2000	2200
26.0				1400	1700
28.0					1300
30.0					1000
I	0	0	0	0	0
II	0	6.5	13.0	19.5	26
Reeving	12	6	5	4	3
Hook	60t Hook				

Table14 Unit:kg

Boom Angle (°)	Main Boom (m) + Jib (m)					
	Outriggers fully extended, over sides and rear, 5t + 3t counterweight					
	47.0+9.5			47.0+16.0		
	0°	15°	30°	0°	15°	30°
80	5500	3500	3000	3500	2200	1500
78	5000	3500	3000	3500	2000	1500
76	5000	3300	2800	3200	2000	1500
74	4800	3300	2800	2800	2000	1500
72	4300	3100	2800	2800	1800	1400
70	4000	3000	2700	2600	1600	1400
68	3800	3000	2600	2400	1600	1400
66	3600	2900	2500	2100	1500	1400
64	3300	2700	2400	2000	1500	1300
62	2900	2500	2300	1900	1500	1300
60	2500	2300	2100	1800	1400	1300
58	2200	2100	1900	1700	1400	1200
56	1900	1800	1700	1500	1300	1200
54	1600	1500	1400	1200	1100	1000
52	1300	1200	1100	1000	950	900
50	1100	1000	950	900		
48	1000					
Reeving	1					
Hook	6t Hook					

Note: Those points marked with "*" are only applicable by using 80T hook, and lifting area is over sides and rear. Product specifications are subject to change without notice and obligation. The photographs and/or drawing in this document are for illustrative purposes only. Please consult your local ZOOMLION dealer for more information.

Note: Those points marked with "*" are only applicable by using 80T hook, and lifting area is over sides and rear.